

# STURMTIGER

During World War II the German Army had to combat frequently fortified positions or urban defense centers. Due to tactical reason - the troops were at short distance to the enemy lines - artillery and air support could not be engaged. This led to the development of the "Sturm" - version of the "Tiger" heavy tank (Italeri N. 293). Onto the heavy-duty chassis the efficient and unique 38 cm mortar was mounted, which had a short range but enormous fire power. Only few units of the Sturmtiger were built and were mainly used in 1994 at the Eastern front.

**Technical Data:** Length: 6,28 m; Width: 3,57 m; Height: 2,85 m; Weight: 65 tons; Range of vehicle: 120 km; Crew: 5; Armament: one 38 cm mortar RW6, one 7,92 mm machinegun.

Während des zweiten Weltkrieges mußte die Deutsche Wehrmacht oft befestigte Stellungen oder Bunker im Stadtinneren unter Beschuß nehmen und konnte auf Grund der Nähe der eigenen Truppen nicht auf Artillerie und Luftwaffe zurückgreifen. Dies führte zur Entwicklung einer Sonderversion des Panzerkampfwagens "Tiger" (Italeri Nr. 293) mit der Bezeichnung "38 cm RW61 auf Sturm-morser Tiger". Auf das robuste Chassis wurde der effiziente 38 cm Morser montiert, der eine geringe Reichweite aber einen enormen Zerstörungseffekt hatte. Nur wenige Exemplare des Sturmtiger wurden hergestellt und Ende 1944 vorwiegend an der Ostfront eingesetzt.

**Technische Daten:** Länge: 6,28 m; Breite: 3,57 m; Höhe: 2,85 m; Gewicht: 65 t; Reichweite: 120 km; Besatzung: 5 Bewaffnung: 1 x 38 cm Morser RW61, 1 x 7,92 mm MG.

Durant la 2<sup>de</sup> G.M., l'armée Allemande devait fréquemment combattre les positions fortifiées ou les centres de défense urbains. Pour des raisons techniques - les troupes n'étaient pas loin des lignes ennemies - l'artillerie et le support aérien ne pouvaient être utilisés. Ceci mena au développement du "Sturm" - version du "Tiger" tank lourd (Italeri N. 293). Sur le lourd chassis a été monté un efficace mortier de 38 cm, qui a une courte portée mais une énorme puissance de feu. Seulement quelques unités du Sturmtiger furent construites et elles furent principalement utilisées en 1944 sur le front Est.

**Données Techniques:** Longueur: 6,28 m; Largeur: 3,57 m; Hauteur: 2,85 m; Poids: 65 t; Autonomie: 120 km; Equipage: 5; Armement: 1 mortier 38 cm RW 61, 1 mitrailleuse 7,92 mm.

Durante la 2<sup>a</sup> Guerra Mundial, el ejército alemán tuvo que combatir frecuentemente, contra posiciones fortificadas, o centros de defensa urbana. Debido a razones tácticas - las tropas se encontraban a corta distancia de las líneas enemigas - la artillería y el apoyo aéreo no podían ser utilizadas. Esto condujo al desarrollo del "Sturm" - versión del carro pesado "Tiger" (Italeri n° 293). Sobre el pesado chasis se montó el singular eficiente mortero de 38 cm., que era de corto alcance, pero tenía una enorme potencia de fuego. Únicamente se construyeron unas pocas unidades del Sturmtiger, y fueron principalmente utilizadas en 1944 en el Frente Este.

**Datos Técnicos:** Longitud: 6,28 m; Anchura: 3,57 m; Altura: 2,85 m; Peso: 65 toneladas; Autonomía del vehículo: 120 km; Tripulación: 5; Armamento: un mortero RW61 de 38 cm, una ametralladora de 7,92 mm.

Utilizar el pegamento específico para plástico (poliestereno).  
 Utilizar el pegamento y las pinturas en un ambiente aireado y lejos de fuentes de calor.  
 Para menores de 14 años es aconsejable la asistencia de un adulto.



Pegamento sólido (atòxico)  
**MODEL MASTER Ref. 03 996**

El pegamento sólido en tubo (atòxico) se extiende mediante la punta del tubo.



Pegamento líquido (tòxico)  
**MODEL MASTER Ref. 03 999**

El pegamento líquido (tòxico) se extiende con el pincelito.

**A ITALERI**

**DISTRIBUIDOR EXCLUSIVO:**

**CASA GALAN, S.A.**

P.JE. DELS GARROFERS, 12  
 08021 BARCELONA

T: 932000136 • FX: 932021568

<http://www.hobbygalan.com>



**(E) INFORMACION IMPORTANTE SOBRE ESTA MAQUETA**

- ① Juguete no apto para menores de 3 años. Las partes pequeñas podrían ser ingeridas o aspiradas.
- ② Presencia de extremidades apuntadas funcionales al montaje del modelo mismo.
- ③ Tenga cuidado al utilizar las herramientas y cuchillas de trabajo, ya que pueden causarle daños personales.
- ④ **ATENCIÓN:** Las pinturas recomendadas para esta maqueta son solo para modelistas adultos.



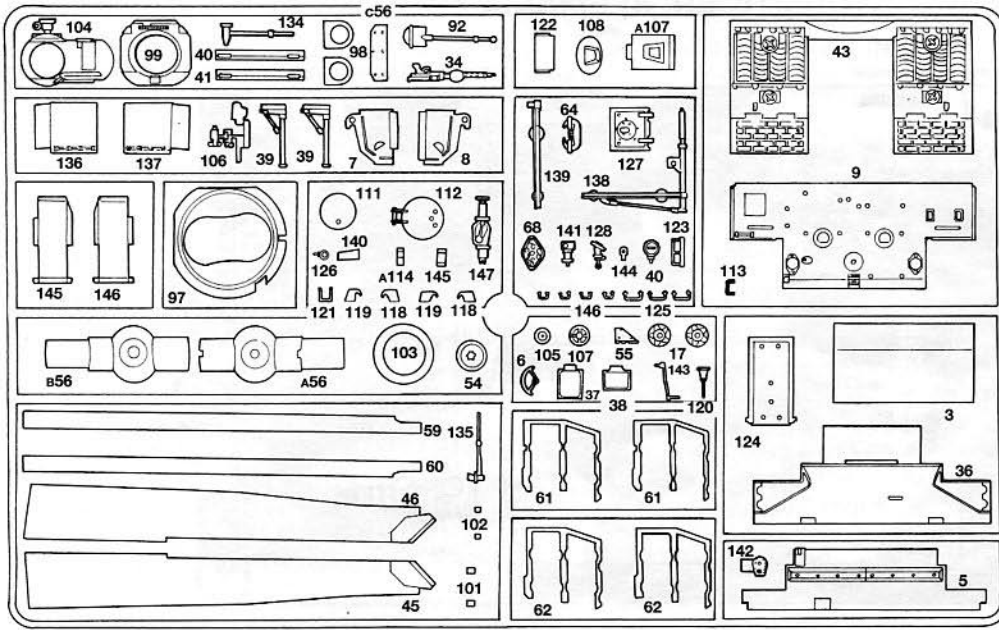

**C**



PERFORAR LOS AGUJEROS

No usar

Instrucciones de pintado: Los números de código de color son los de las pinturas ITALERI **MODEL MASTER**

**A**

1749 MODEL MASTER  
F.S. 37038  
Flat Black  
Schwarz (M)  
Nero (O)  
Noir Mat (M)  
Negro Mate  
E 9983

**B**

1546 MODEL MASTER  
Silver  
Silber  
Argento  
Argent  
Plata  
E 8352

**C**

1785 MODEL MASTER  
Rust  
Rost  
Ruggine  
Rouille  
Herrumbre  
E 6683

**D**

1747 MODEL MASTER  
F.S. 17038  
Gloss Black  
Schwarz (G)  
Nero (L)  
Noir Brillant (B)  
Negro Brillante  
E 9971

**E**

1723 MODEL MASTER  
F.S. 36118  
Gunship Gray  
Dunkelgrau (M)  
Grigio Blu Scuro (O)  
Gris Narire de Guerre (M)  
Gris Azul Oscuro  
E 8743

**F**

1712 MODEL MASTER  
F.S. 34097  
Field Green  
Feldgrün (M)  
Verde Erba (O)  
Vert Herbe (M)  
Verde Hierba  
E 7633

**G**

1405 MODEL MASTER  
Gun Metal (Metalizer)  
Stahlblau (Metalizer)  
Metallo Scuro (Metalizer)  
Gris Metal (Metalizer)  
Metal / Cañon

**H**

1735 MODEL MASTER  
Wood  
Holz (M)  
Legno (O)  
Bois (M)  
Madera  
E 6313

**I**

1745 MODEL MASTER  
F.S. 17875  
Insignia White  
Signalweiss (G)  
Bianco Segnale (L)  
Blanc Insignes (B)  
Blanco Brillante  
E 0041

**L**

1736 MODEL MASTER  
Leather  
Leder (M)  
Cuoio (O)  
Cuir (M)  
Cuero Mate  
E 6562

**1**

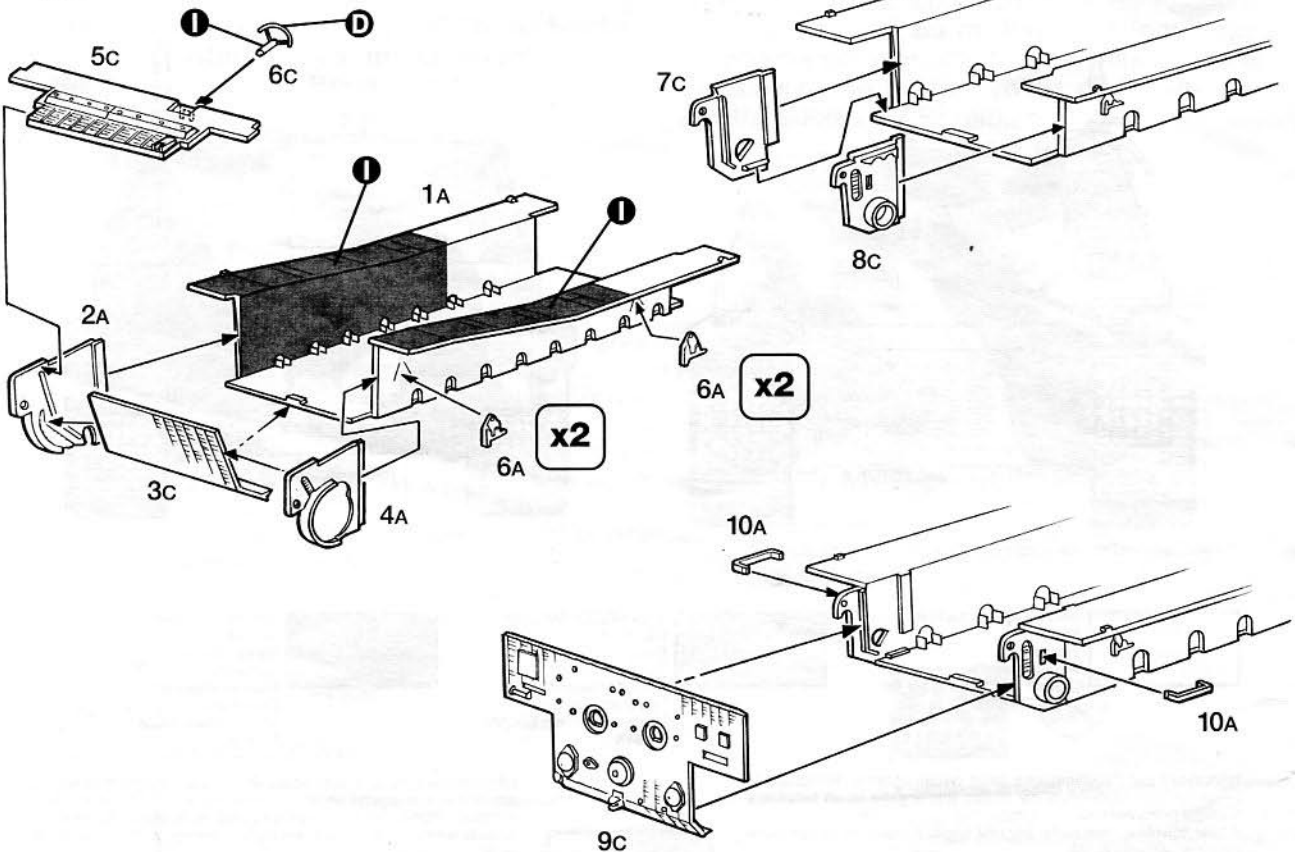

**A**

**B**

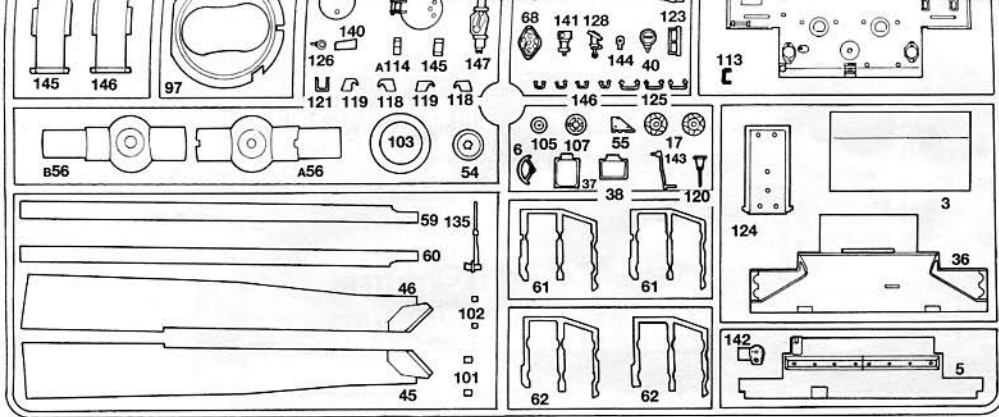

Instrucciones de pintado: Los números de código de color son los de las pinturas ITALERI **MODEL MASTER**

**A**

1749 MODEL MASTER  
F.S. 37038  
Flat Black  
Schwarz (M)  
Nero (O)  
Noir Mat (M)  
Negro Mate  
E 9983

**B**

1546 MODEL MASTER  
Silver  
Silber  
Argento  
Rouille  
Plata  
E 8352

**C**

1785 MODEL MASTER  
Rust  
Rost  
Ruggine  
Rouille  
Herrumbre  
E 6683

**D**

1747 MODEL MASTER  
F.S. 17038  
Gloss Black  
Schwarz (G)  
Nero (L)  
Noir Brillant (B)  
Negro Brillante  
E 9971

**E**

1723 MODEL MASTER  
F.S. 36118  
Gunship Gray  
Dunkelgrau (M)  
Grigio Blu Scuro (O)  
Gris Narire de Guerre (M)  
Gris Azul Oscuro  
E 8743

**F**

1712 MODEL MASTER  
F.S. 34097  
Field Green  
Feldgrün (M)  
Verde Erba (O)  
Vert Herbe (M)  
Verde Hierba  
E 7633

**G**

1405 MODEL MASTER  
Gun Metal (Metalizer)  
Stahlblau (Metalizer)  
Metallo Scuro (Metalizer)  
Gris Metal (Metalizer)  
Metal / Cañon

**H**

1735 MODEL MASTER  
Wood  
Holz (M)  
Legno (O)  
Bois (M)  
Madera  
E 6313

**I**

1745 MODEL MASTER  
F.S. 17875  
Insignia White  
Signalweiss (G)  
Bianco Segnale (L)  
Blanc Insignes (B)  
Blanco Brillante  
E 0041

**L**

1736 MODEL MASTER  
Leather  
Leder (M)  
Cuico (O)  
Cuir (M)  
Cuero Mate  
E 6562

**1**

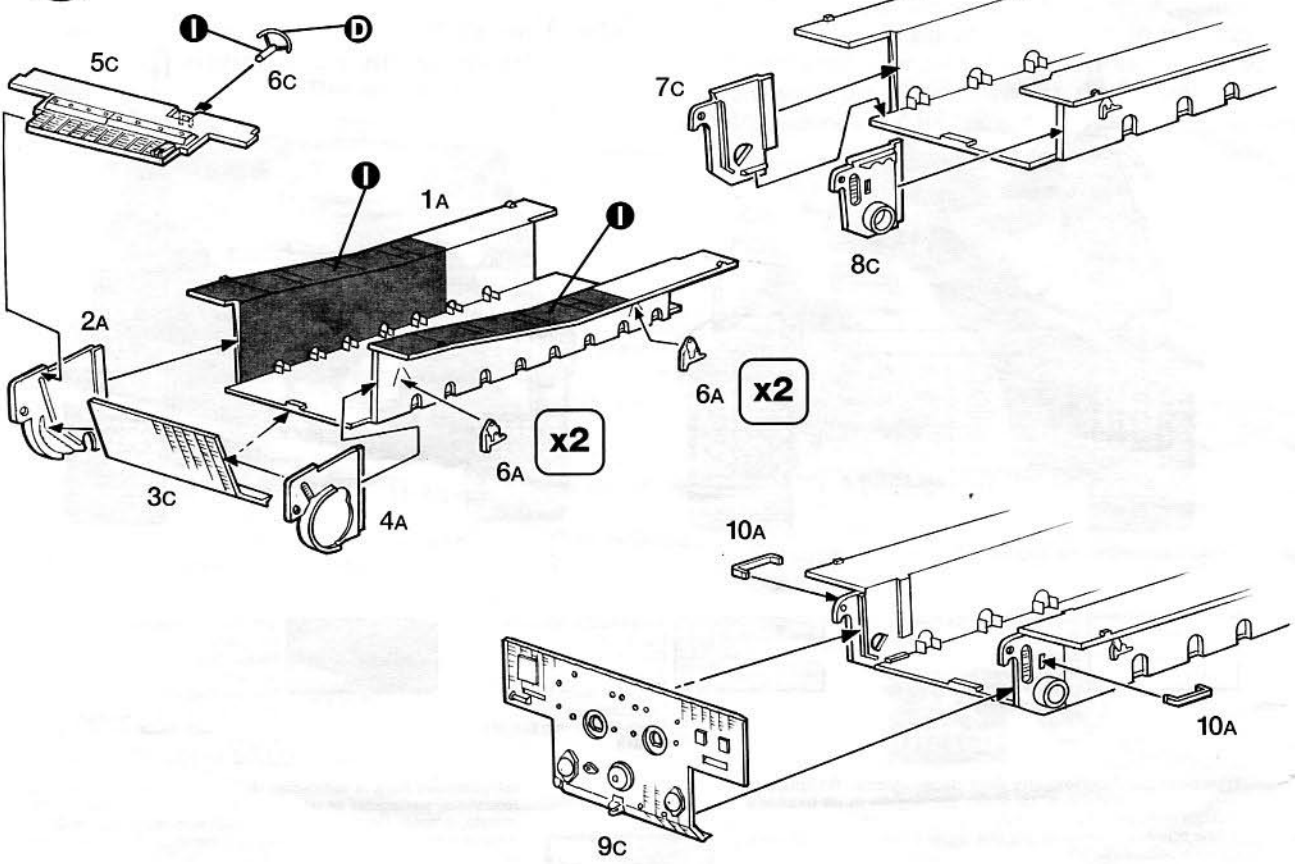

**A**

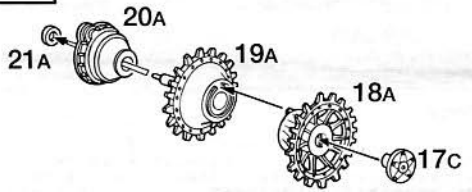

**B**

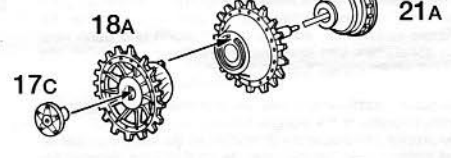

2

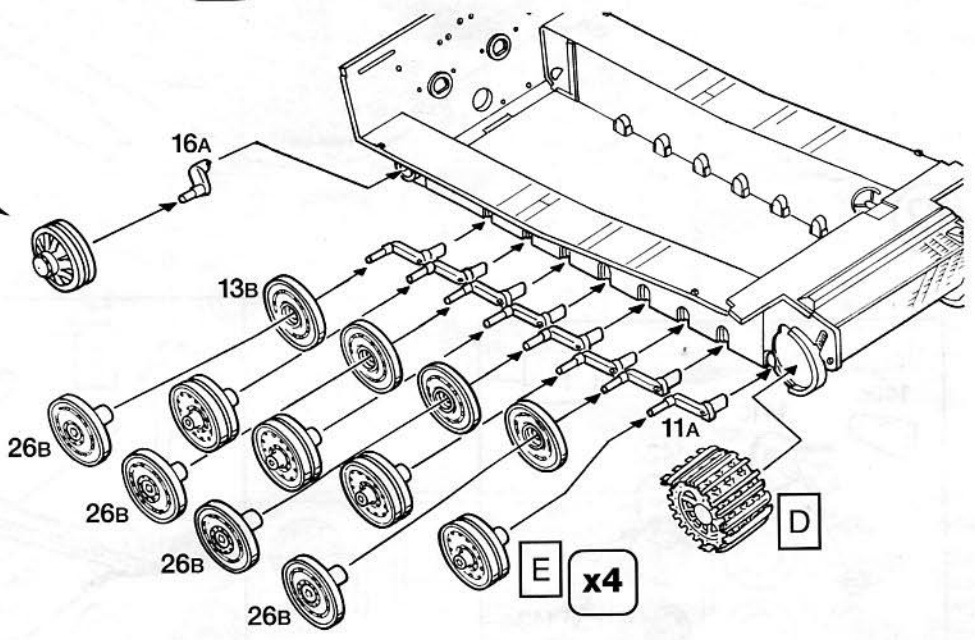
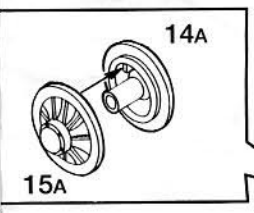
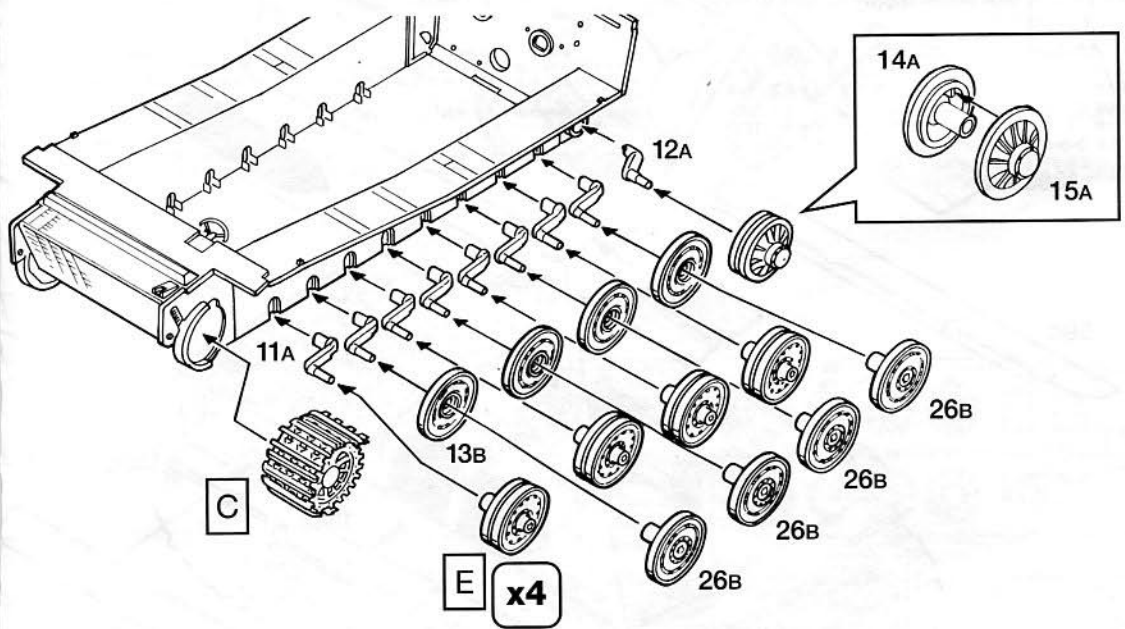
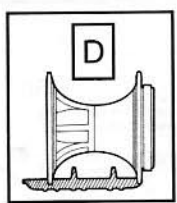
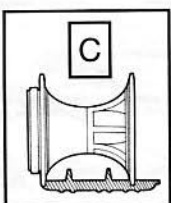
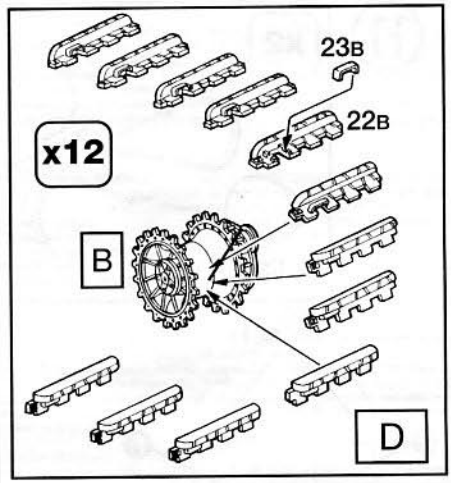
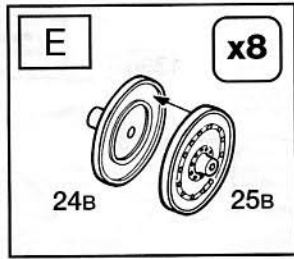
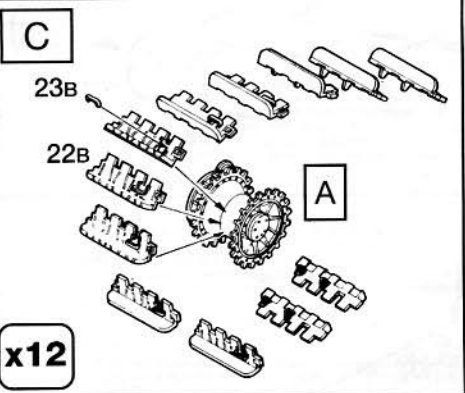

3

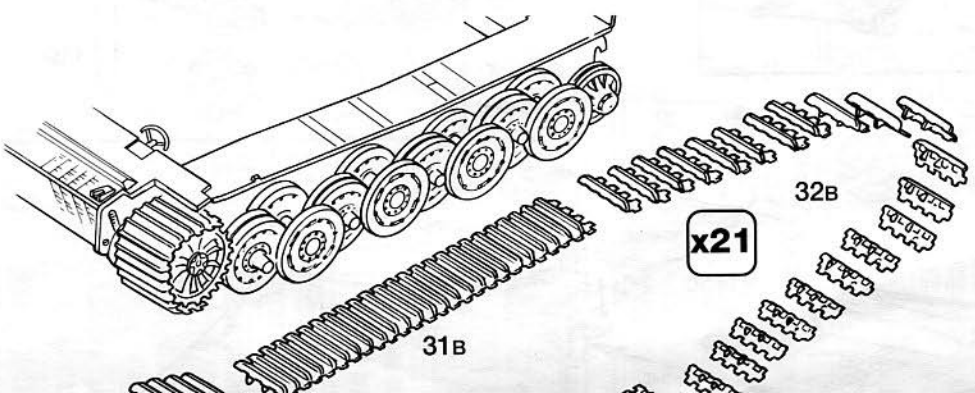



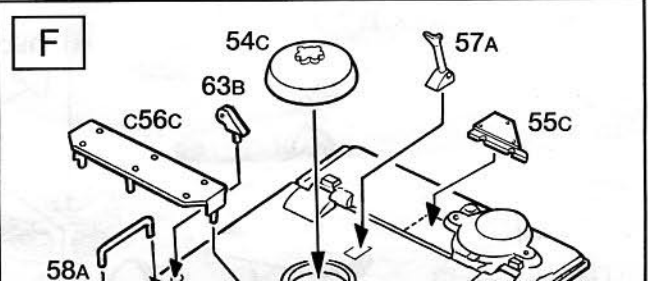
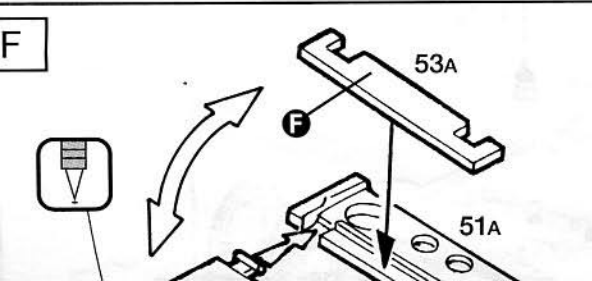
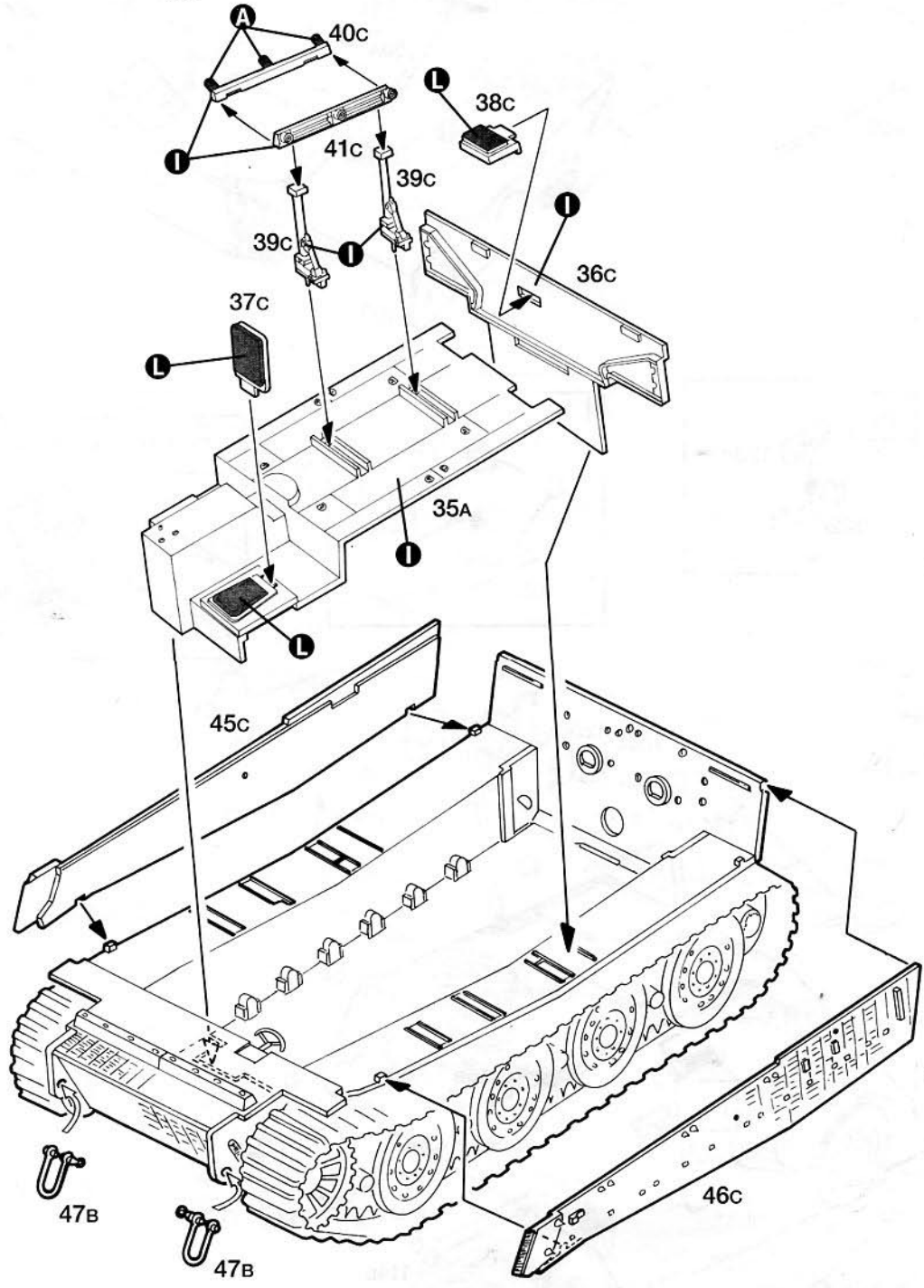
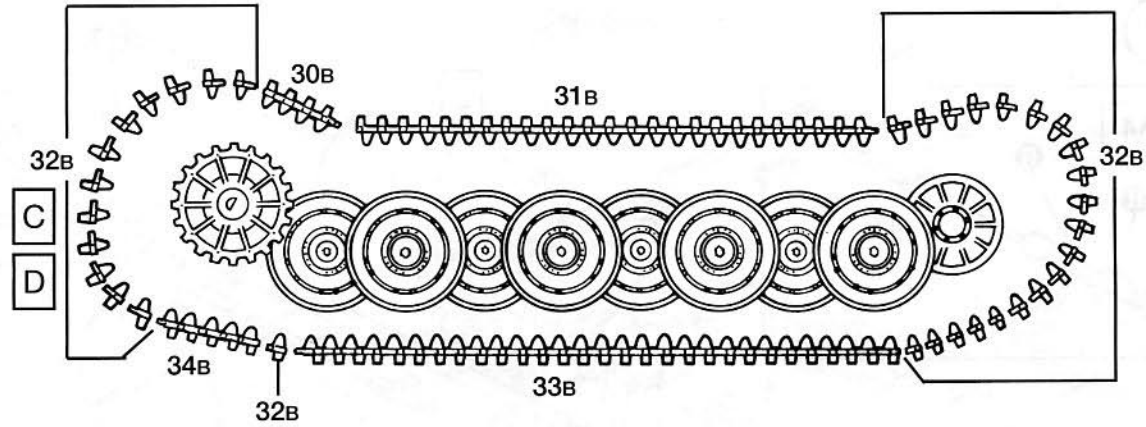

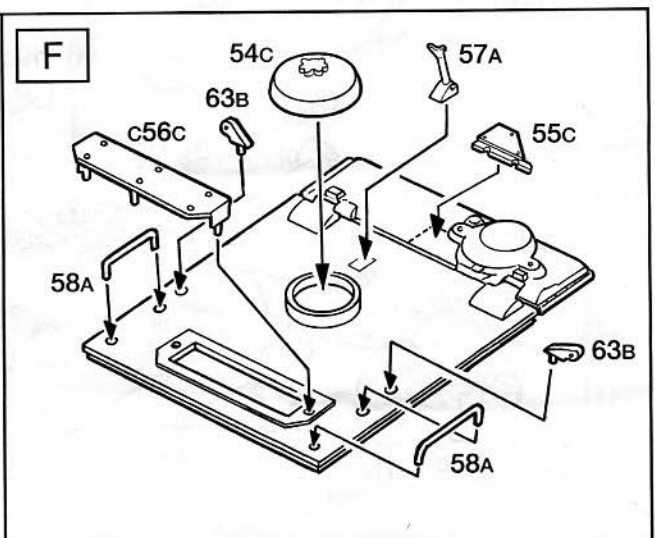
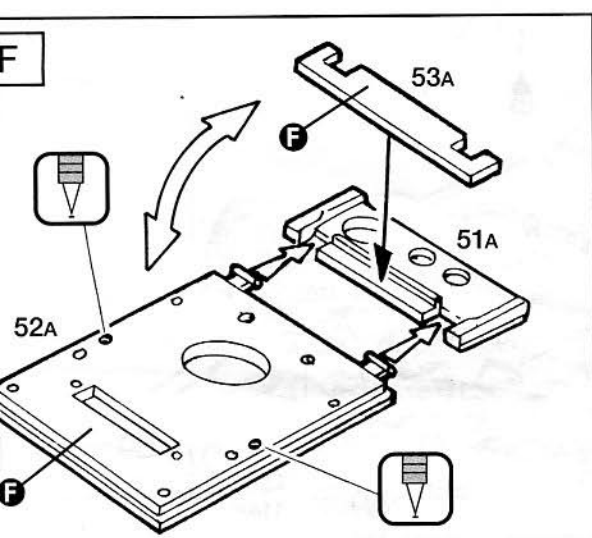
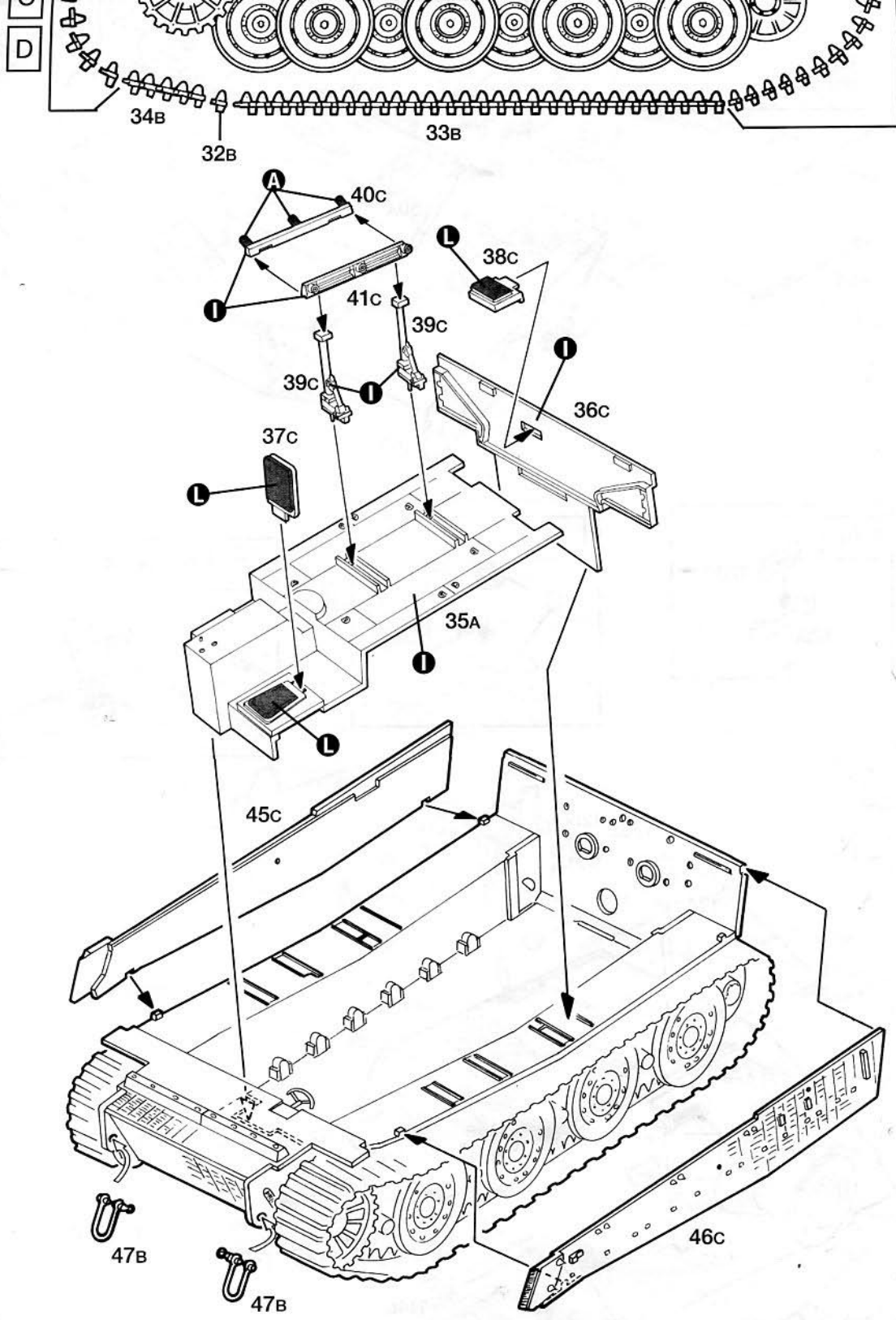

5

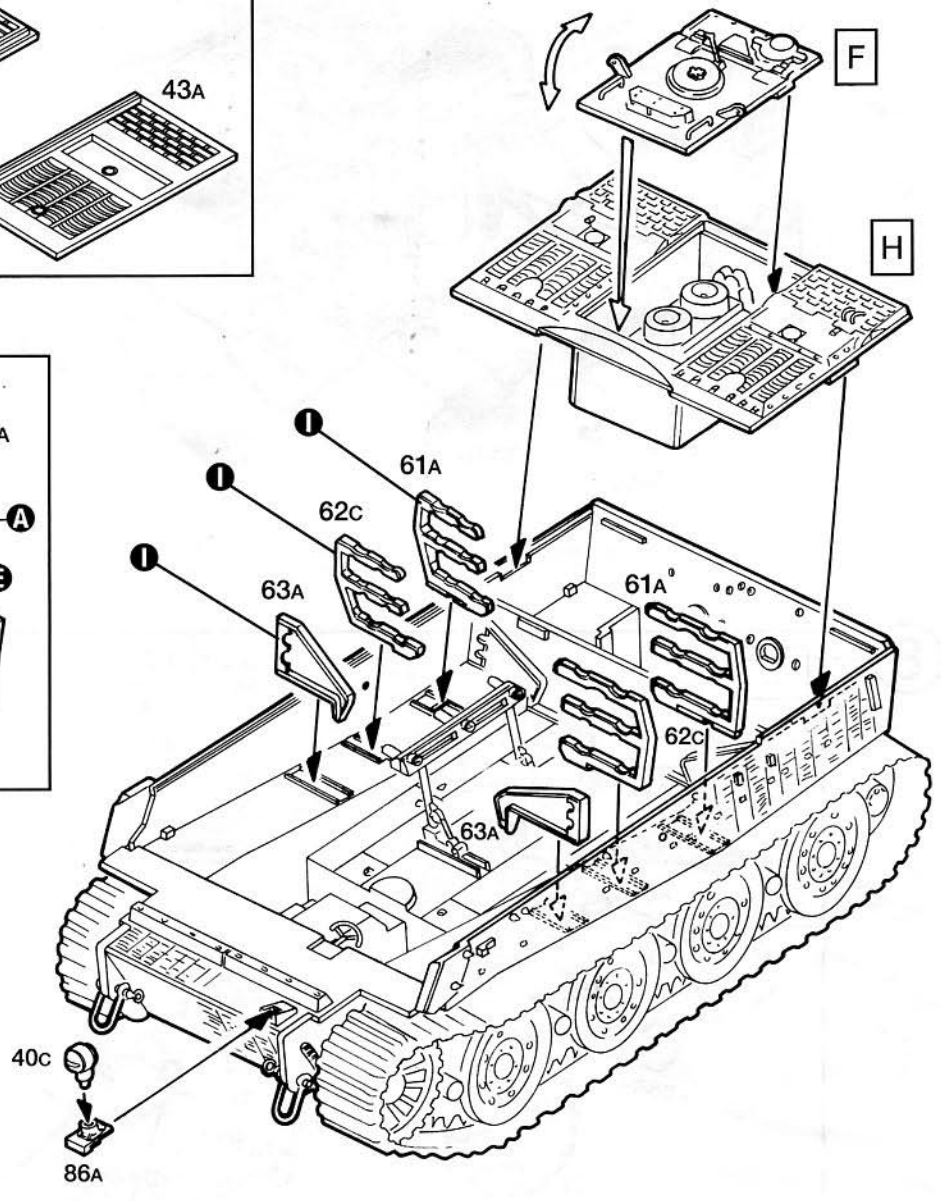
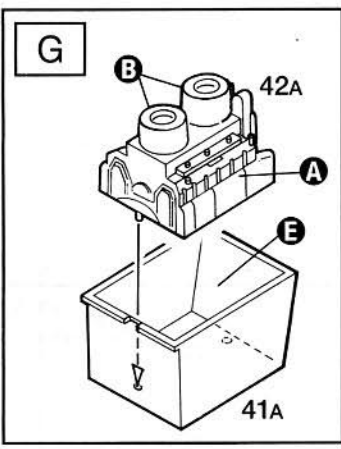
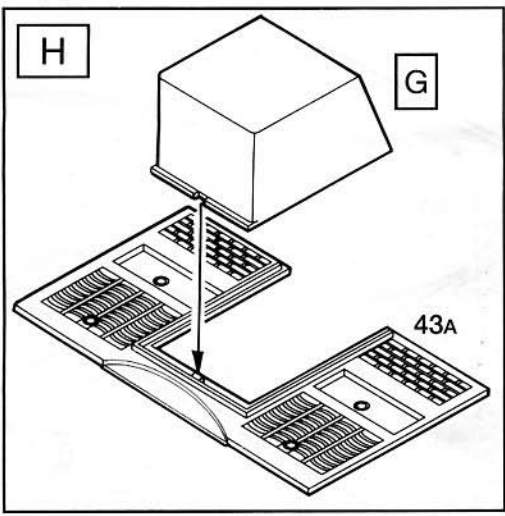

6

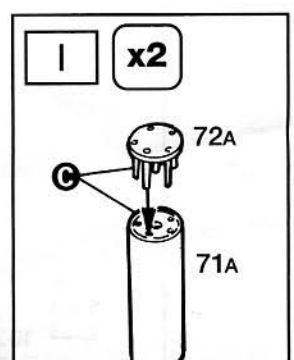
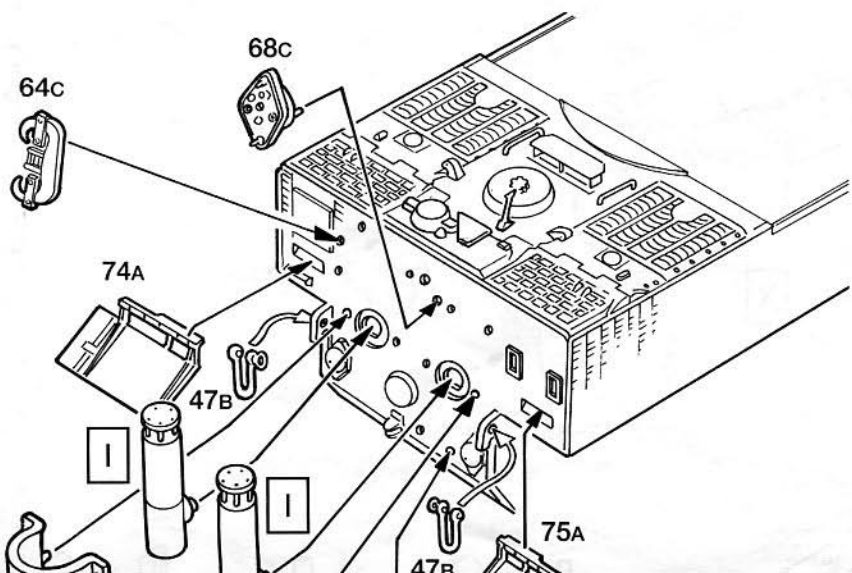

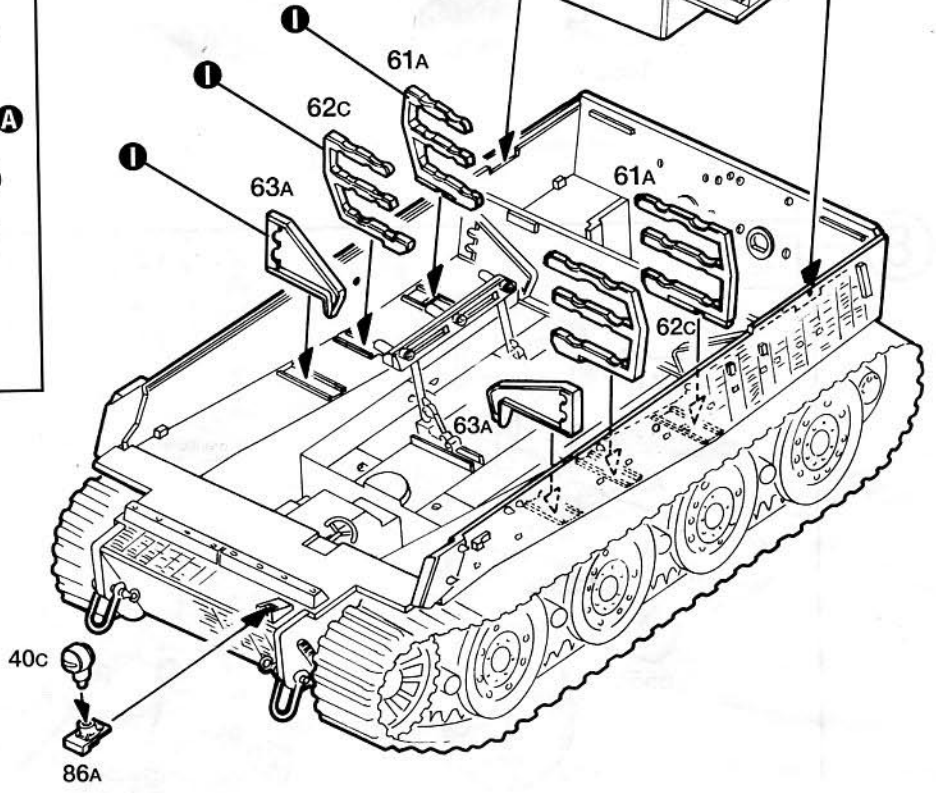
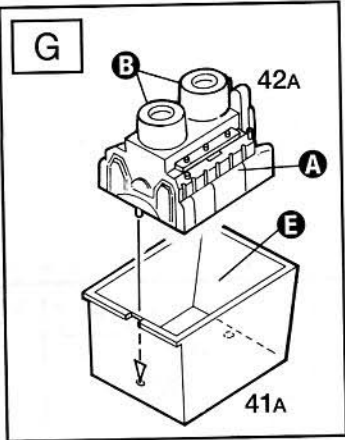
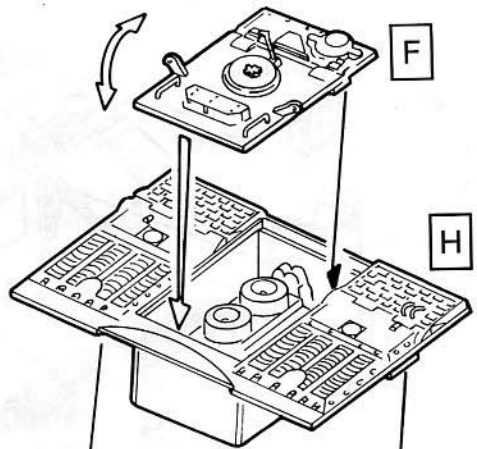
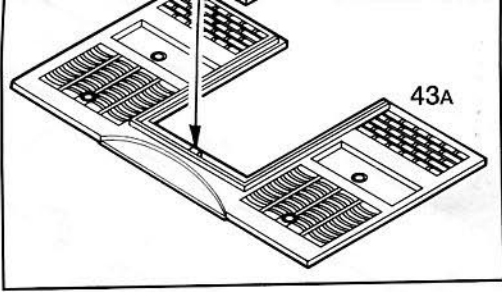

6

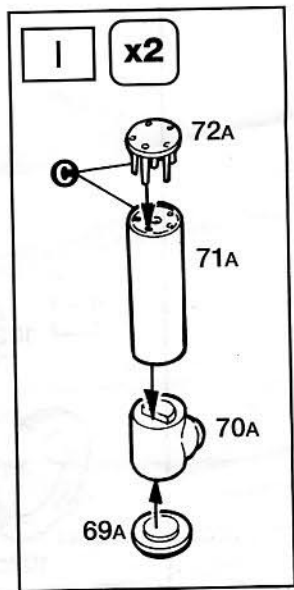
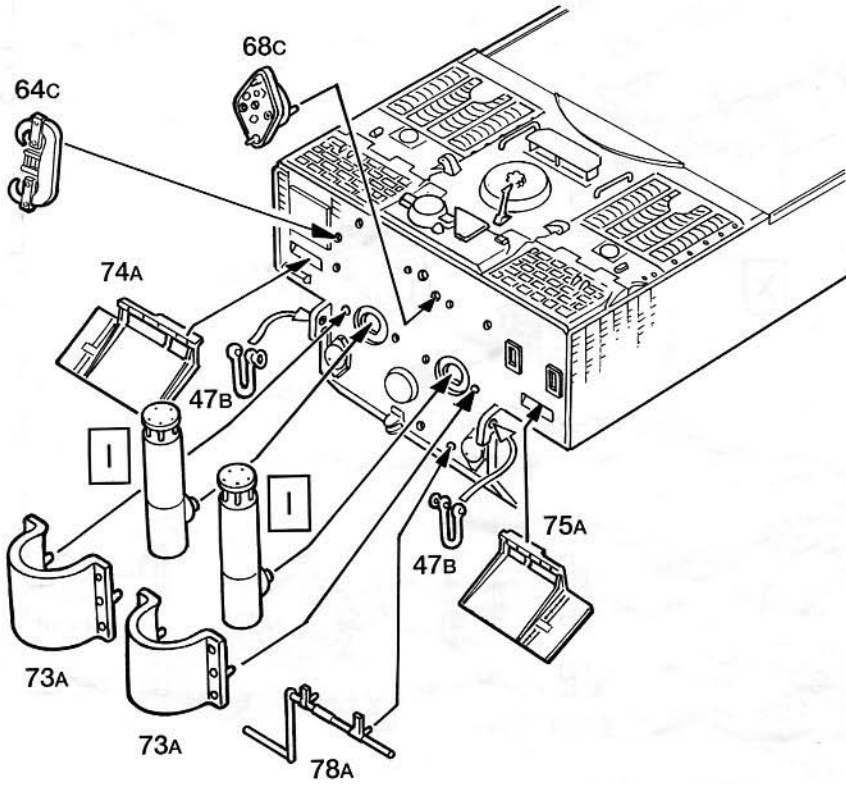

7

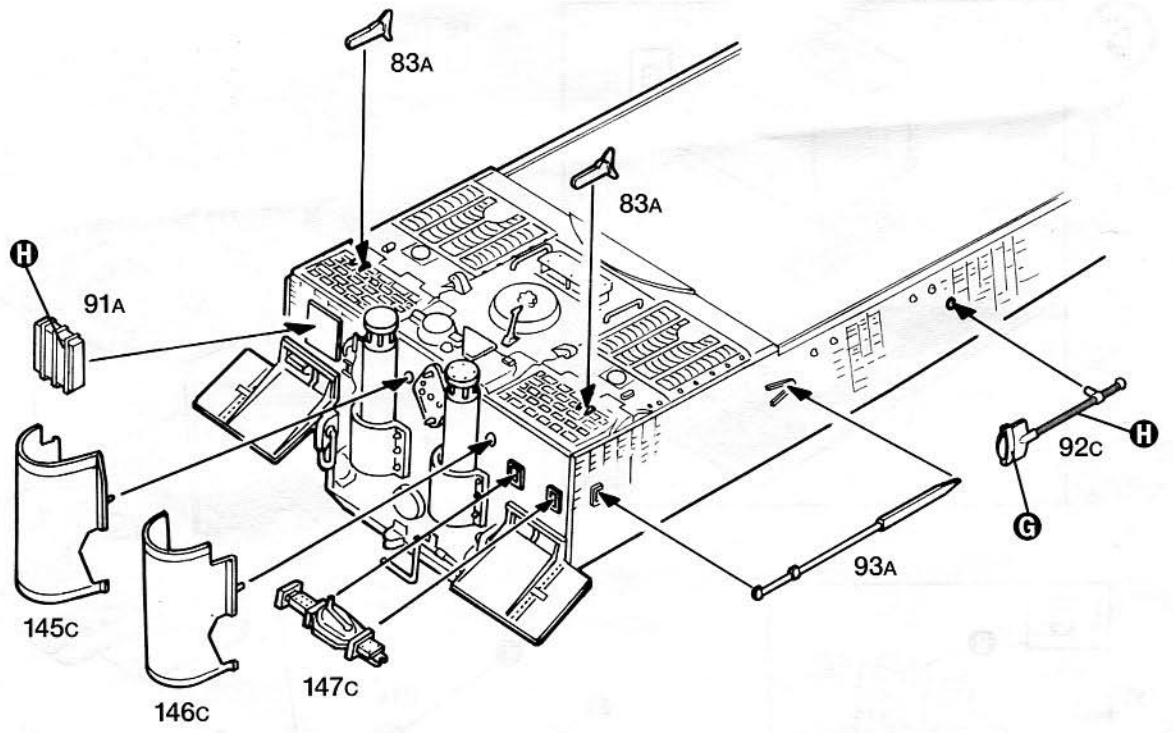

8

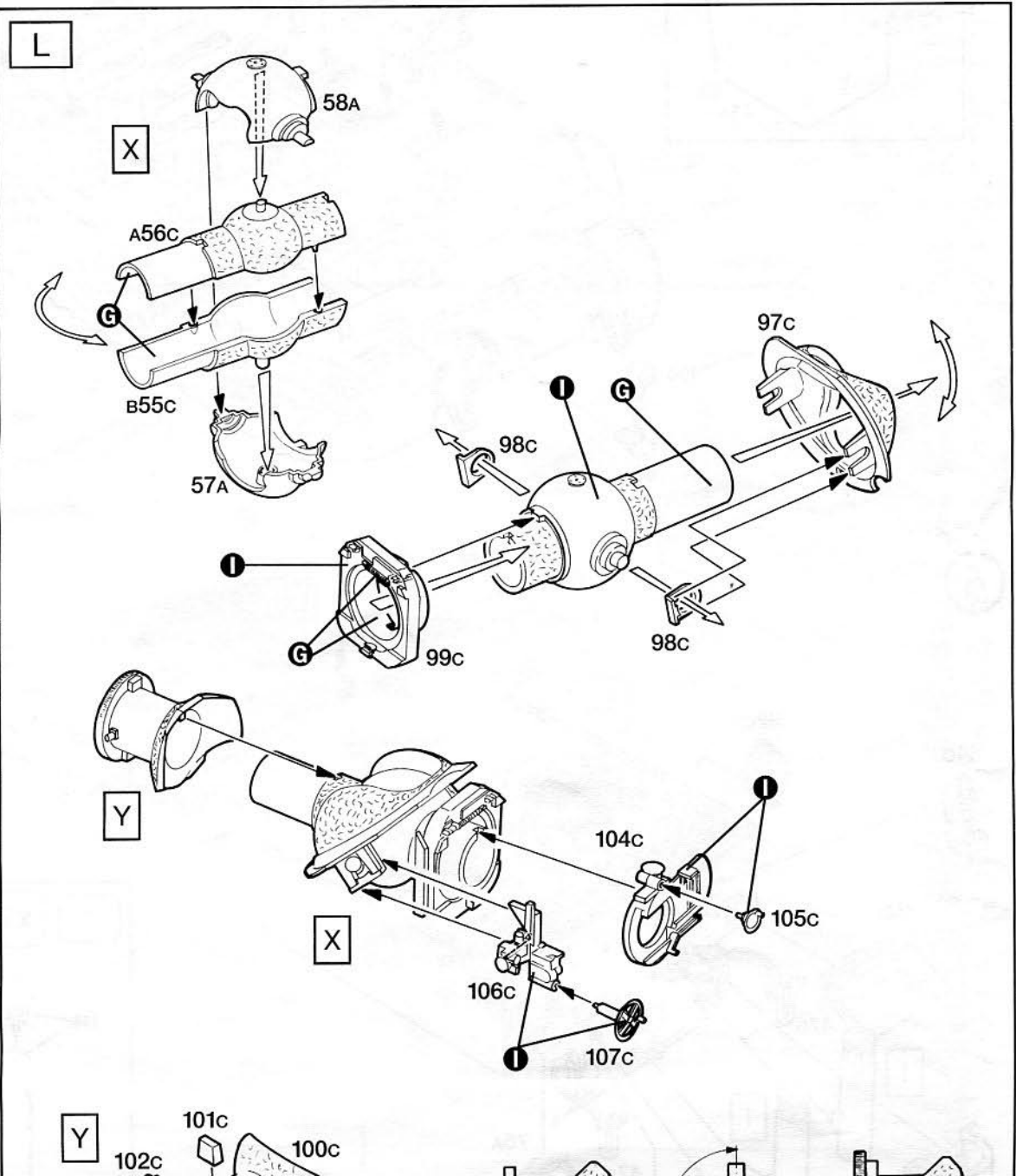

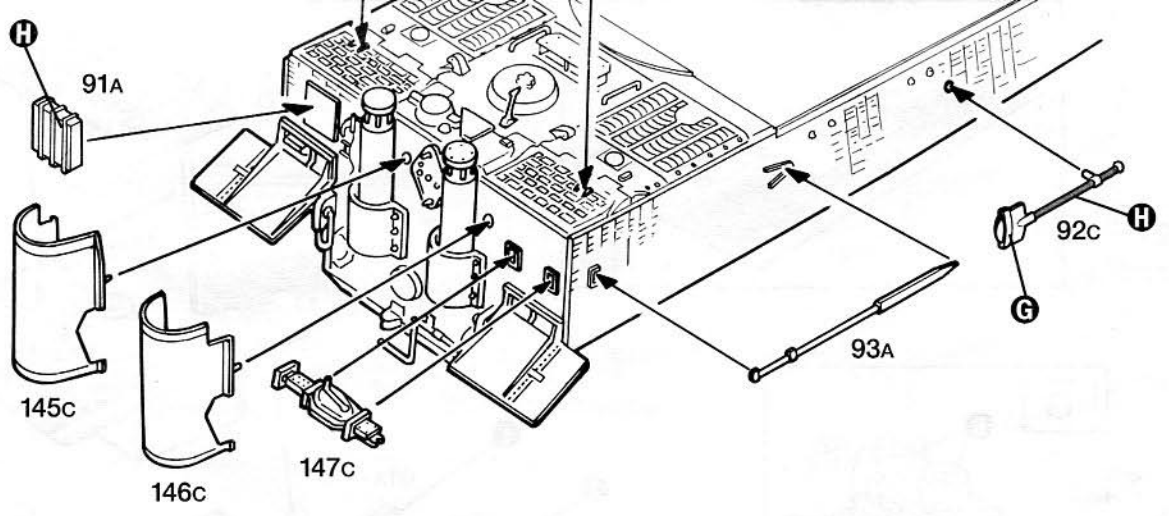

8

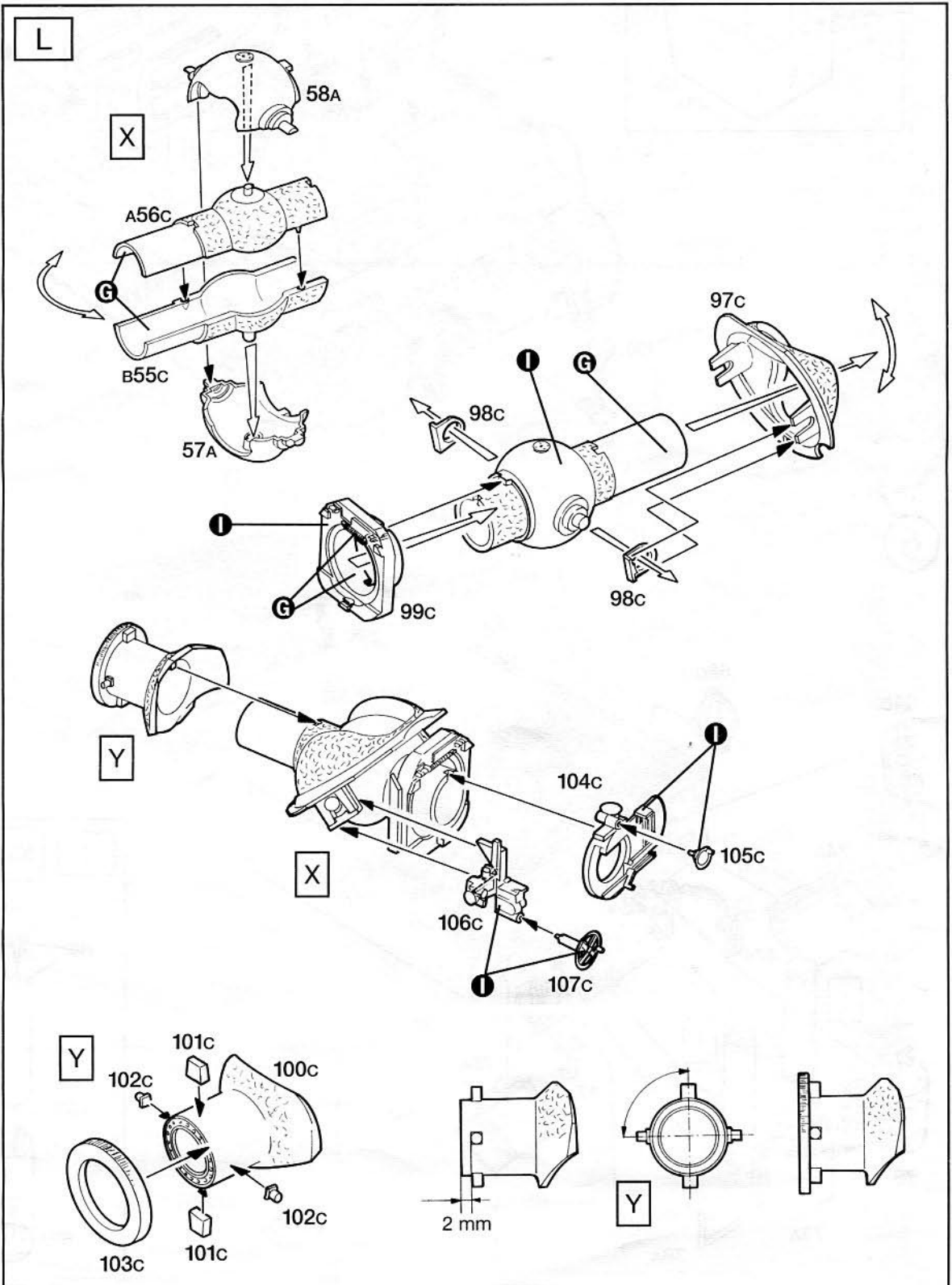

9

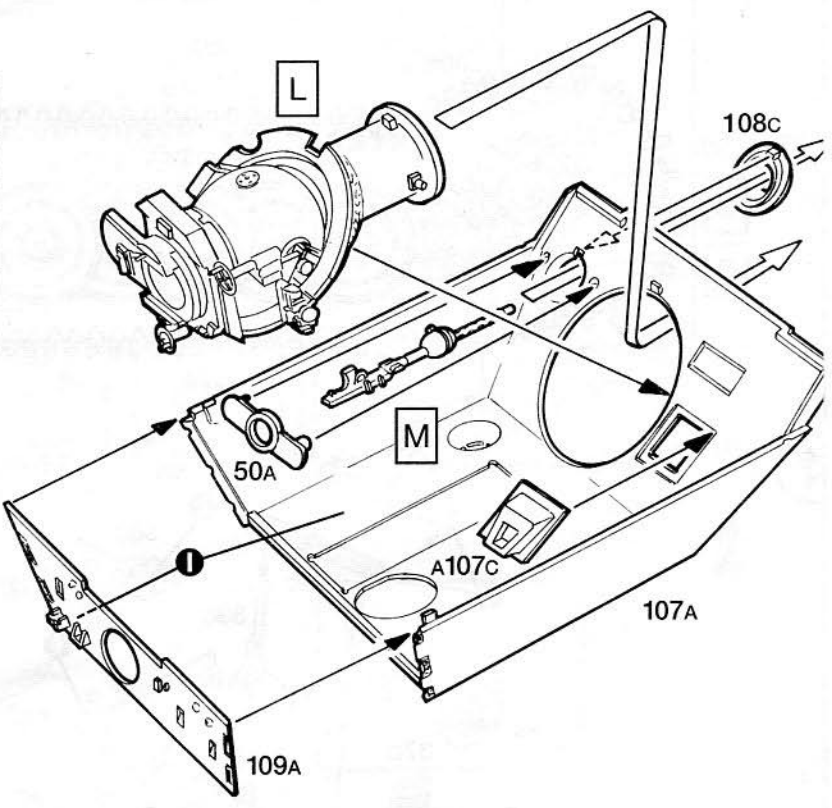
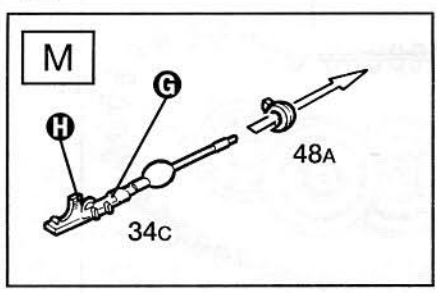

10

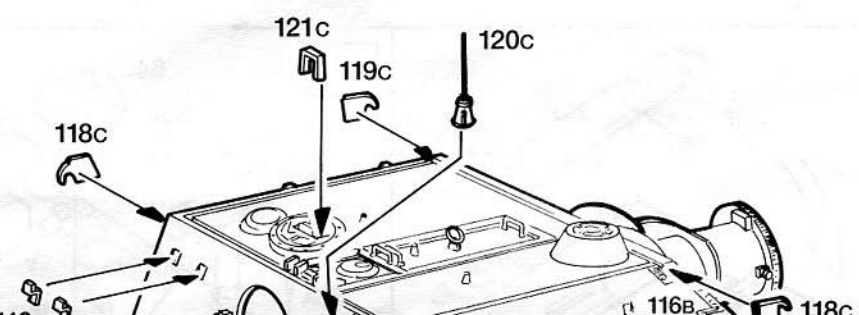
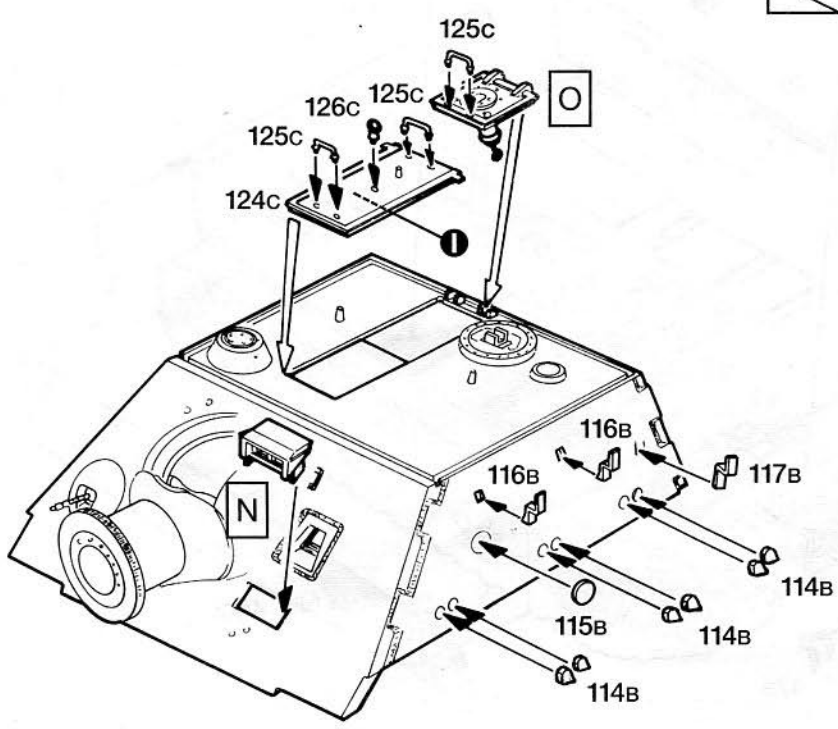
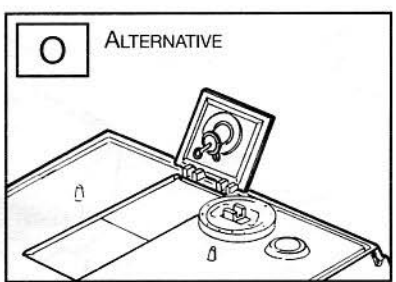
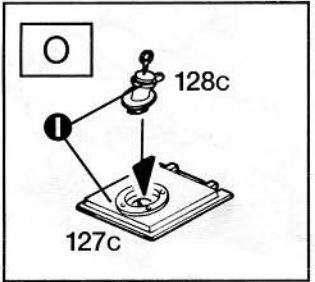
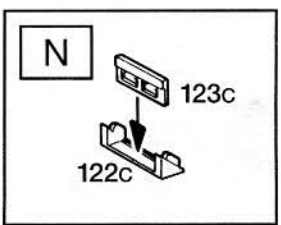

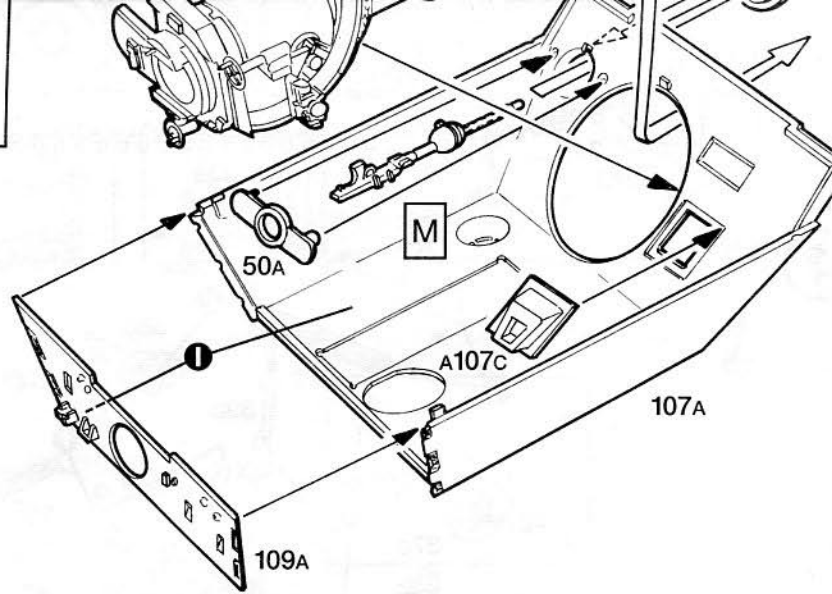
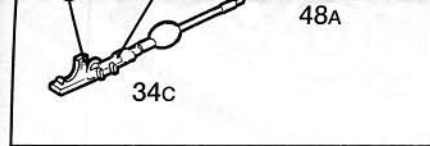

10

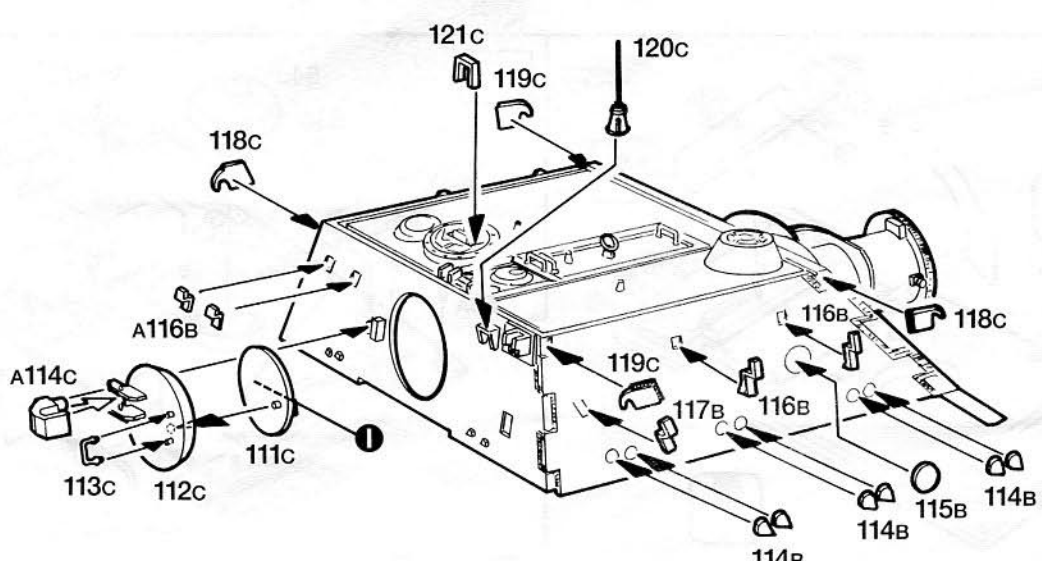
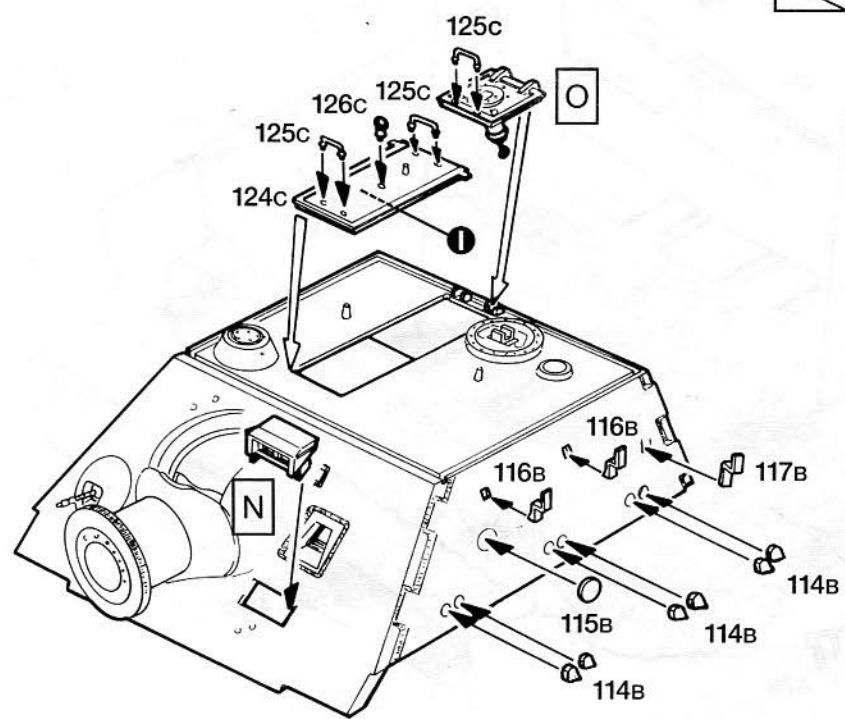
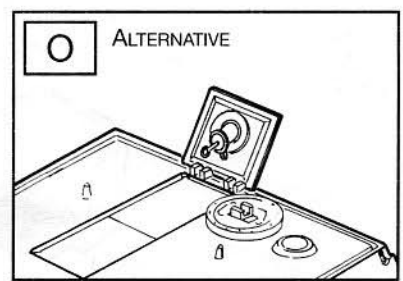
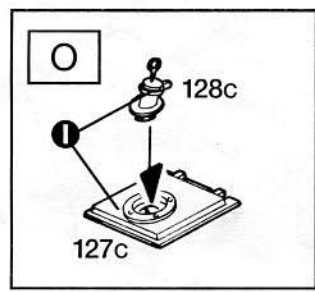
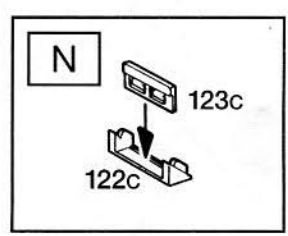

11

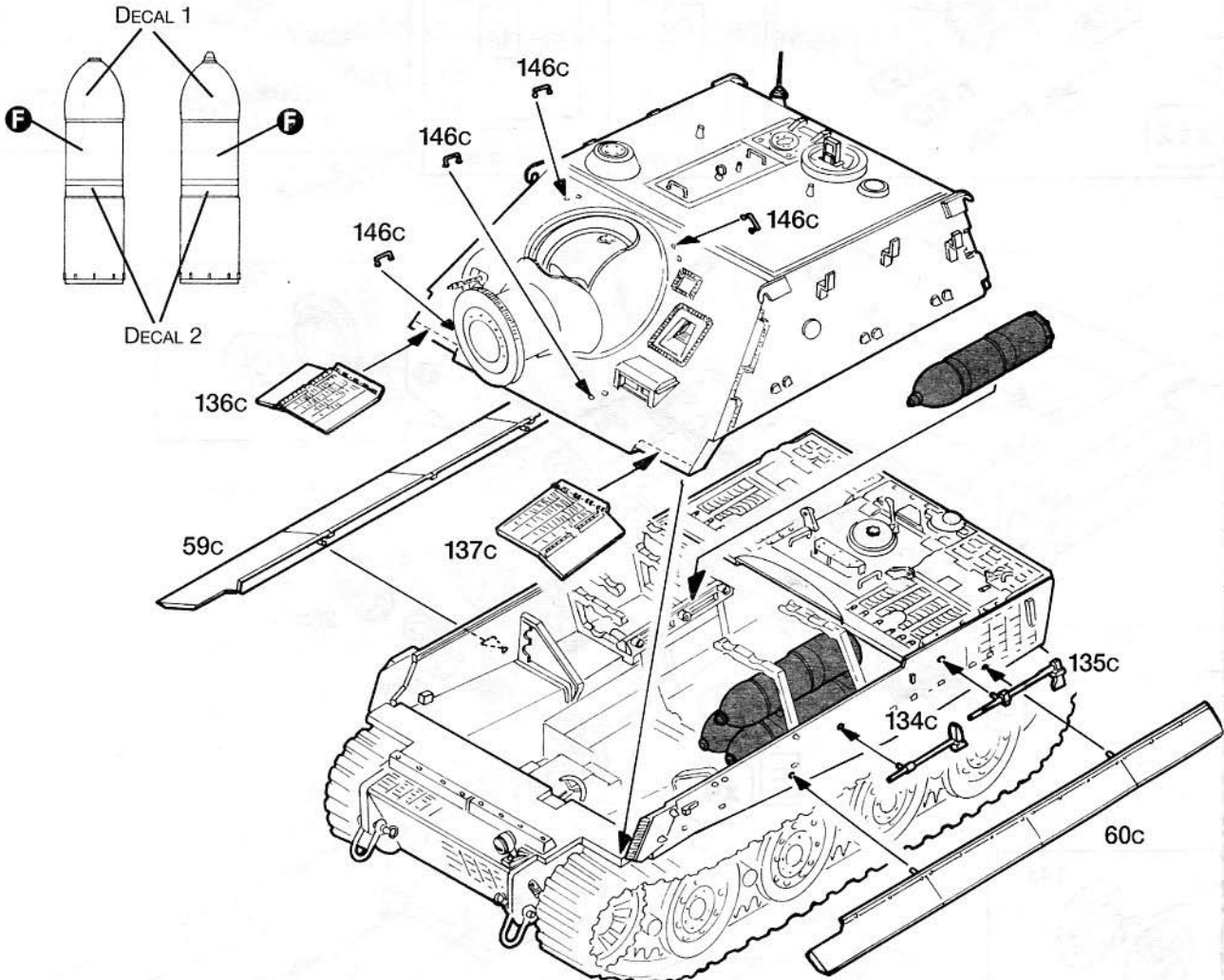
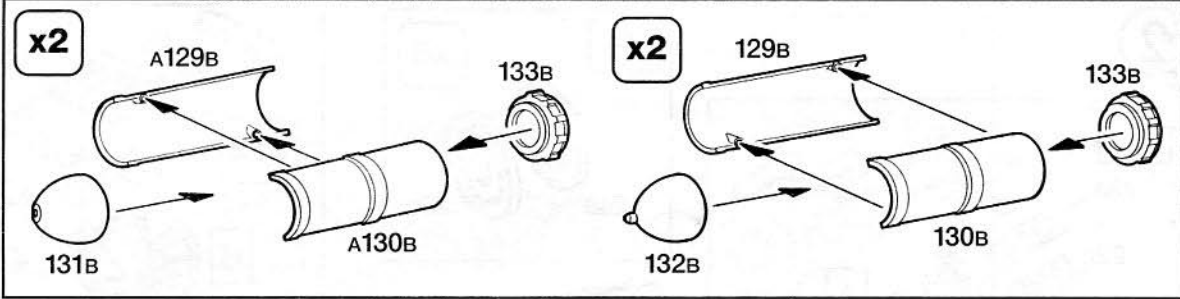

12

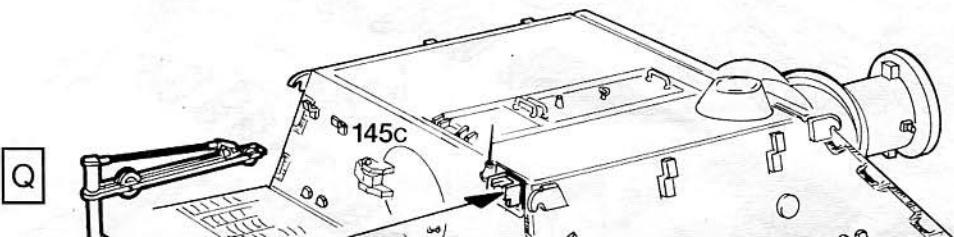
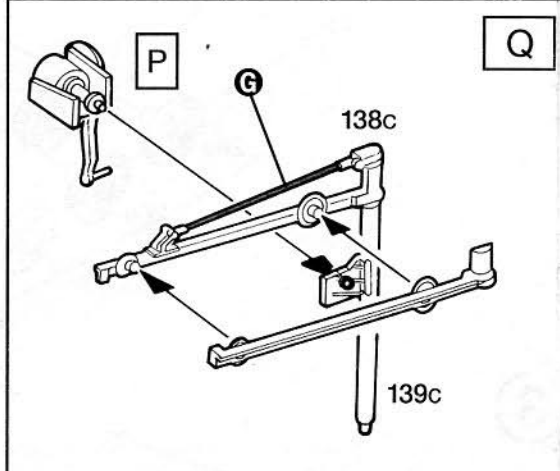
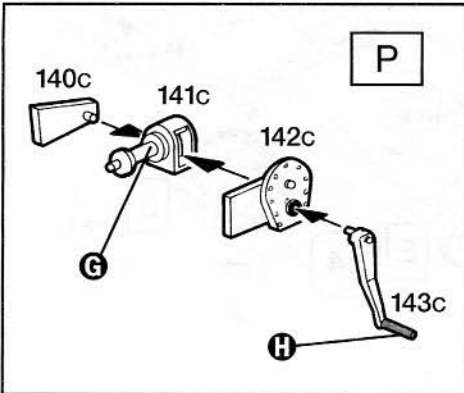

131B

A130B

132B

130B

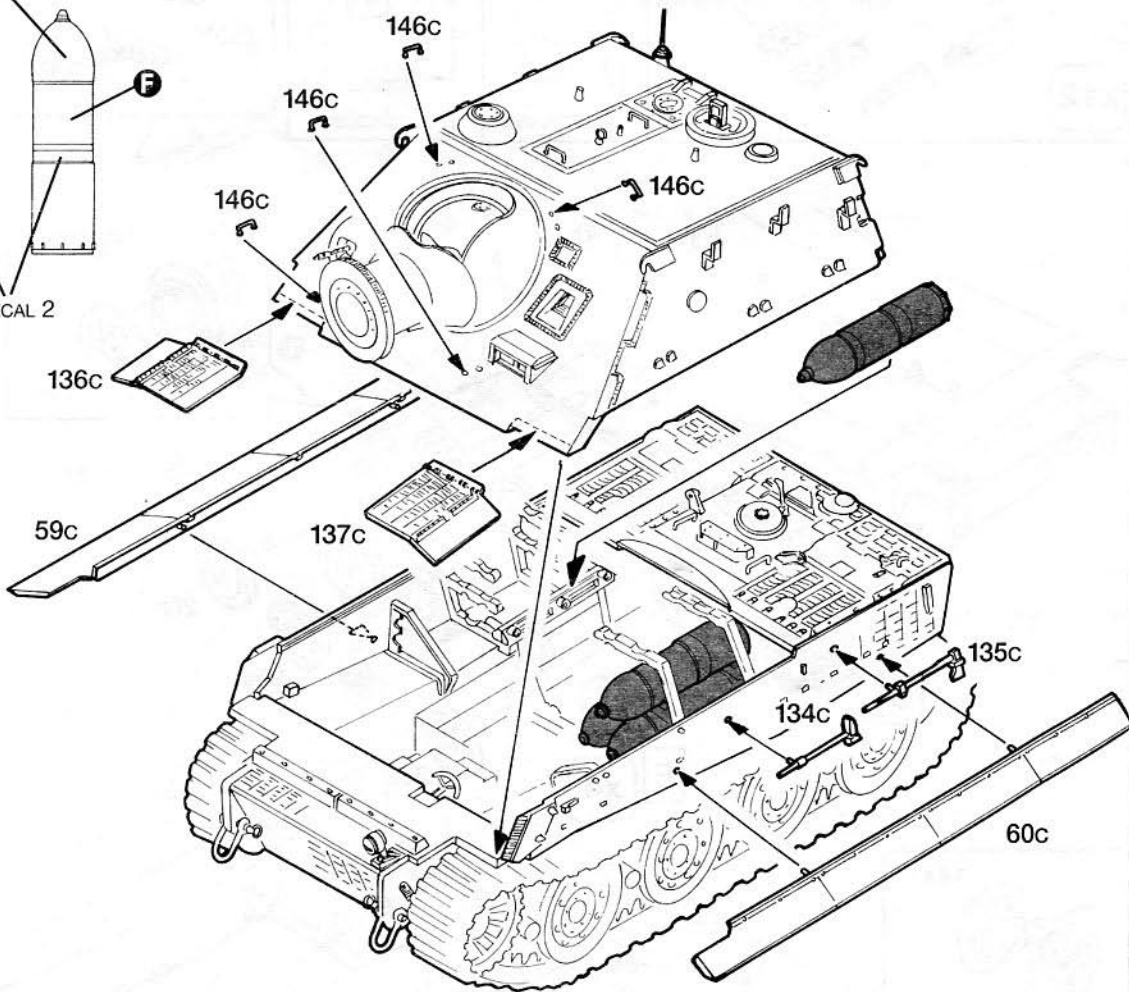
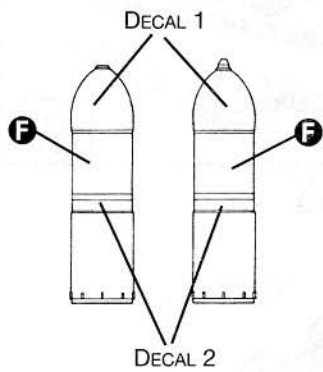

12

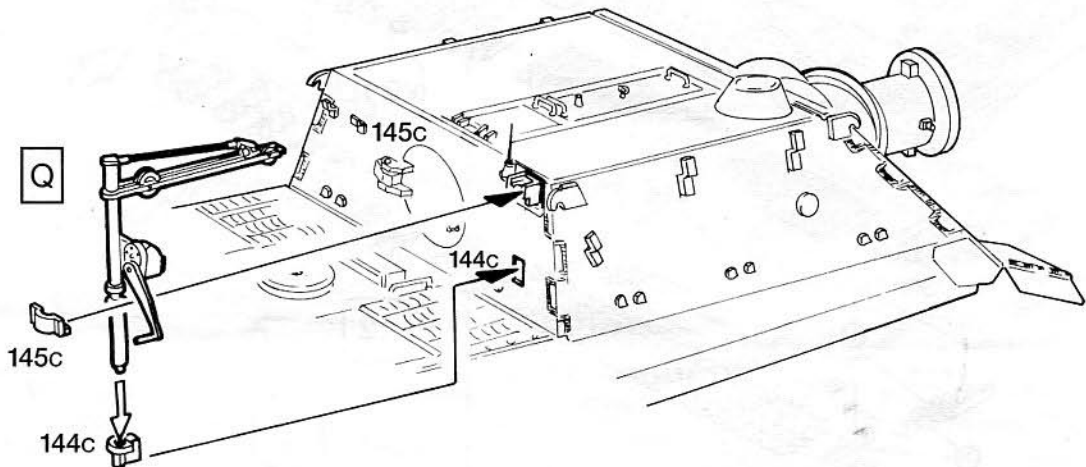
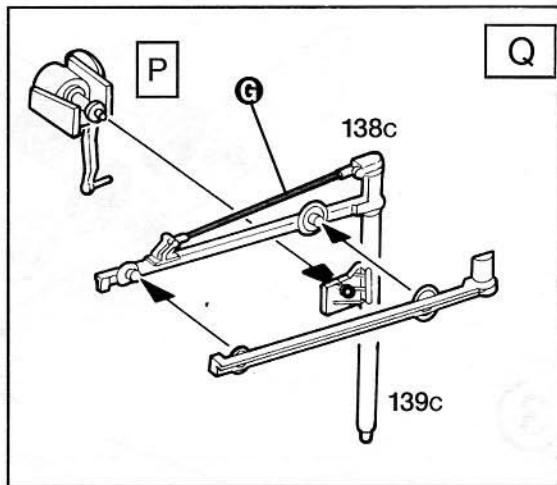
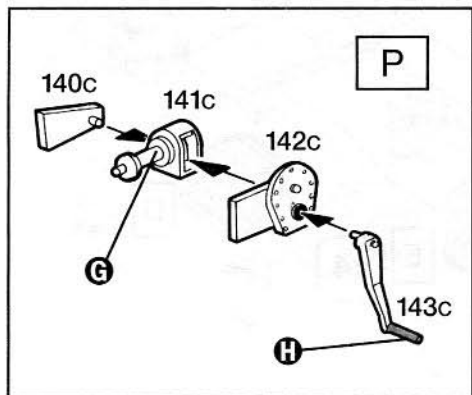

# STURMTIGER, ALEMANIA 1945

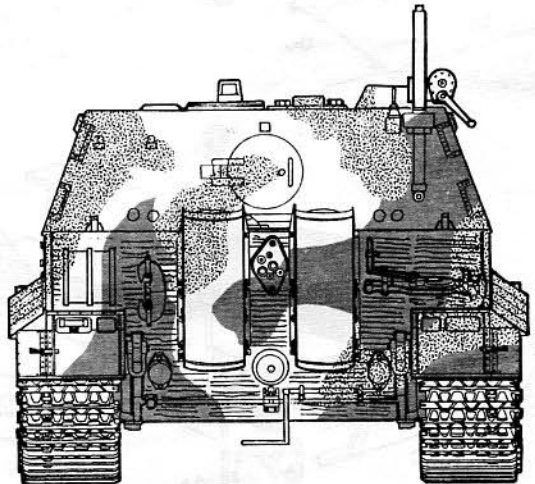
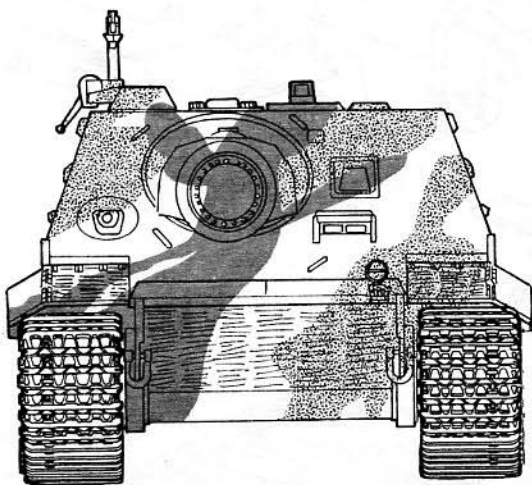
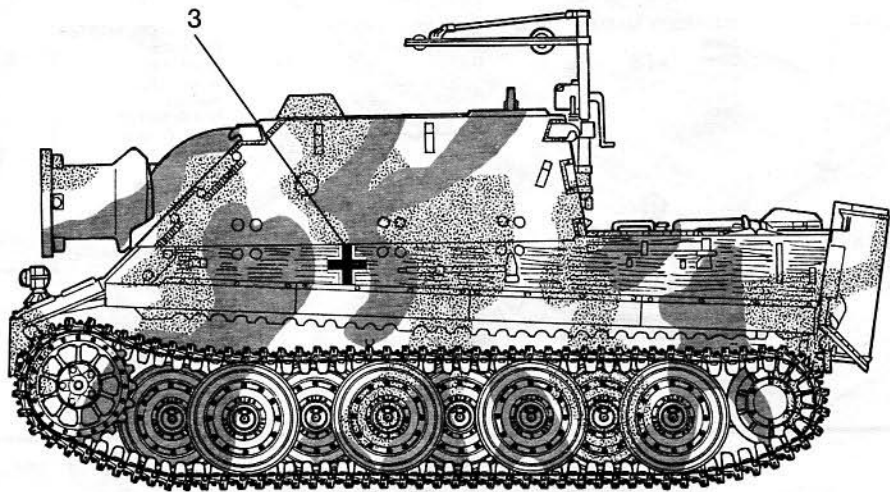
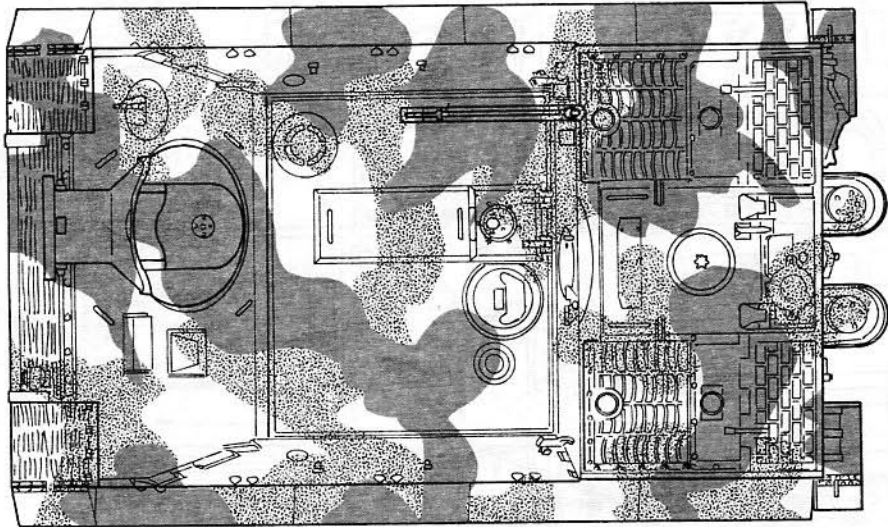

1567 MODEL MASTER  
Flat Tan  
Erde (M)  
Terra Chiara (O)  
Couleur de Chêne Terne (M)  
Tierra Clara

1764 MODEL MASTER  
F.S. 34092  
European Green  
Tarngrün (M)  
Verde Mimetico Eur. (O)  
Vert Européen (M)  
Verde Mimetismo Eur. Mate  
E 7913

1701 MODEL MASTER  
F.S. 30117  
Military Brown  
Militärbraun  
Marrone Militare (O)  
Brun Militaire (M)  
Marrón Militar Mate  
E 6473

**Istruzioni per l'applicazione delle decalcomanie.** Ritagliare le decalcomanie occorrenti dal foglio, immergerle in un bicchiere d'acqua pulita per circa 1/2 minuto, metterle in posizione sul modello e farle scivolare dalla carta: per una migliore aderenza comprimerle con una pezzuola pulita.

**Directions for applying the decals:** Cut the required decals out of the sheet; dip them into a glass of clean water for about 1/2 minute; position the decals on the kit; letting them slide from the paper. For a



**Istruções** Para a aplicação de las calcomanías: cortar las requeridas, sumergirlas en un recipiente de agua limpia durante 1/2 minuto, colocar las calcomanías sobre el modelo, haciéndolas deslizar sobre el papel. Para una mejor adherencia, presionarlas con un trapo limpio.

**Transfers:** Knip het benodigde deel uit, dempel het ca. 1/2 minuut onder water, houdt het transfer tegen het model en schuif het vanaf